

# Crankcase Assembly

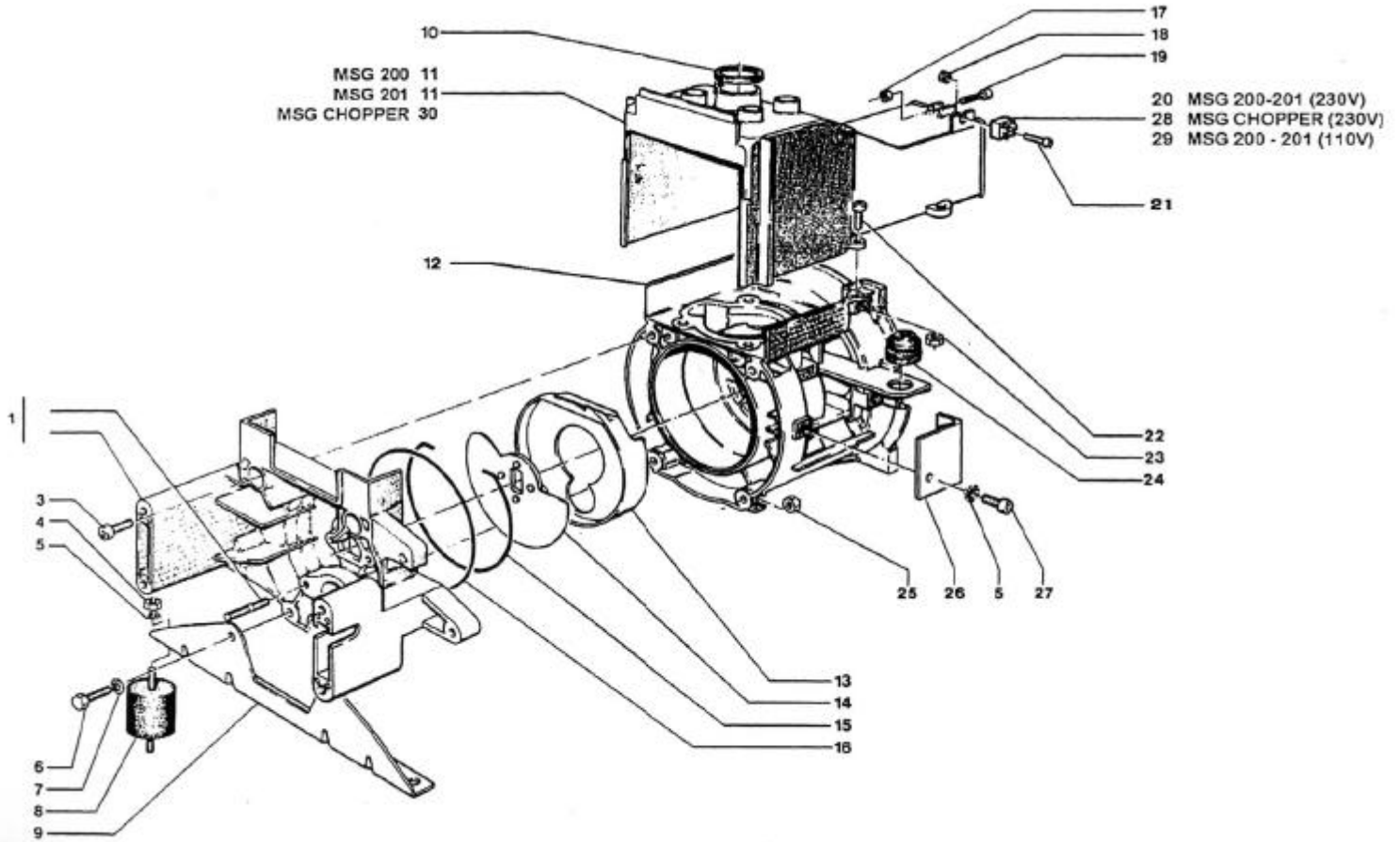

REF	PART NUMBER	DESCRIPTION	PRICE	REF	PART NUMBER	DESCRIPTION	PRICE
01	101092700	FLANGE, CARB. HOLDER	\$ 66.85	16	1018030	O' RING	\$ 3.59
03	6008040	SCREW	\$ .30	17	6022040	NUT	\$ .35
04	6022040	NUT	\$ .35	18	6022020	NUT	N/A
05	6044040	WASHER	N/A	19	6008040	SCREW	\$ .30
06	6001170	SCREW	N/A	20	1270070	DIODE BRIDGE 230V	N/A
07	6040020	WASHER	N/A	20	1270040	DIODE BRIDGE 110V	\$ 15.71
08	101091270	VIBRATION DAMPER	\$ 9.41	21	6008130	SCREW	\$ .23
09	101045540	BRACKET	\$ 6.61	22	6008040	SCREW	\$ .30
10	101043340	GASKET	\$ 3.56	23	6022040	NUT	\$ .35
11	101043330	AIR DUCT	N/A	24	101043810	SUPPORT, FLEXIBLE	\$ 2.52
12	101091300	ENGINE, HOUSING	N/A	25	6022040	NUT	\$ .35
13	101042490	COMPENSATOR	\$ 9.56	26	201308044	BRACKET	N/A
14	101042600	DISC VALVE	\$ 17.00	27	6001040	SCREW	\$ .18